

SAVAGE A50 LUX

Auto-Darkening Welding Helmet



SAVAGE A50 LUX

Welding Processes

- Oxy Fuel Cutting
- Plasma Cutting
- Grinding
- Welding, GMAW (MIG/MAG)
- Welding, GTAW (TIG)
- Welding, PAW -Plasma Arc Welding
- Welding, SMAW/MMA (Stick)

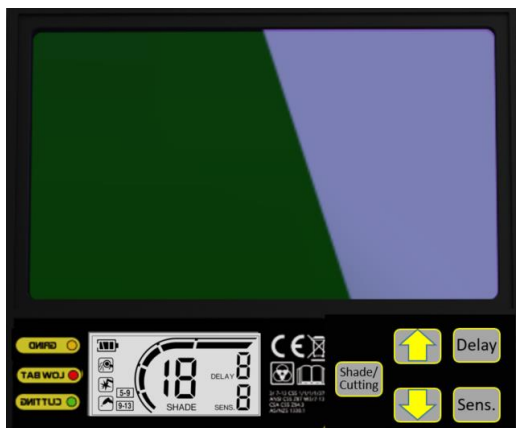

Advanced CE 1/1/1/1 ADF technology with a simple interface and clear graphic display.

The Savage A50 LUX borrows from proven Sentinel A60 welding helmet performance to deliver advanced OpTCS™ true-color viewing at a flawless EN 1/1/1/1 optical level. The ADF features a simple, intuitive control panel that offers control over the most critical features related to all types of welding: wide shade selection; 5-steps of delay and sensitivity.

Adding to the Savage A50 LUX's versatility, is a 50-lumen, dual LED work-light, integrated behind the moulded front cover lens. The work-light is powered by it's own "AA" battery, which offers long life using the integrated arc sensor, shutting the light off only when an arc or intense light is detected.

The Halo™ headgear found in the Savage A50 LUX, is the same 5-point adjustable solution offered in the Sentinel A60.

- Advanced LED work-light with dedicated arc sensor and power supply
- Easily-accessed LED work-light power button and separate external grind button
- ADF viewing area: 100 x 60 mm (3.94 x 2.36 in.) with internally-adjustable push-button controls
- Shade range: DIN 3/5–13
- ESAB OpTCS™ True-Color Lens Technology
- Arc sensors: 4
- Fast switching time of 0.07 millisecond
- Replaceable CR2450 battery
- Low battery and grind mode LEDs

Visit esab.com for more information.



The well-balanced Savage A50 LUX is built around the proven Sentinel A60 headgear

SAVAGE A50 LUX

Specifications	
Viewing Area	100 x 60 mm (3.94 x 2.36 in.)
Active Lens Shade	5–13
Passive Lens Shade	3
Power Supply – ADF / LED work light	1 CR2450 battery / AA alkaline battery
Arc Sensors	4
Switch Time (Light to Dark)	0.07 ms
Switch Time (Dark to Light)	Digitally adjustable from 0.1 to 0.9 second
CE Optical Classification	1/1/1/1
Standards and Certifications	CE: EN175; EN379; EN166 ANSI: Z87.1 CSA: Z94.3 AS/NZS 1338.1 ISO 16321 +TIG
Weight	575 g (1.27 lbs)

Ordering Information	
Description	Part Number
Savage A50 LUX Helmet	0700500950

Delivery includes: Full helmet assembly, 2 replacement inner lenses, 4 replacement outer lenses, carry bag, and safety manual.

Spare Parts		
1	Savage A50 LUX Front Cover Lens – Clear	0700500953
1	Savage A50 LUX Front Cover Lens - Clear HC*	0700500954
2	Savage A50 LUX Helmet Shell	0700500958
3	Savage A50 LUX Grind / LED Light Pushbuttons	0700500957
4	Savage A50 LUX LED Work Light Assembly	0700500956
5	Savage A50 LUX Auto Darkening Filter (excl. batteries)	0700500952
6	Savage A50 LUX Inside Cover Lens	0700500955
7	Savage A50 LUX / Sentinel A60 Halo Headgear	0700600867
	Savage A50 LUX / Sentinel A60 Universal Hard Hat Adapter	0700600871
	Savage A50 LUX / Sentinel A60 Front Sweat band	0700600869
	Savage A50 LUX Magnifying Lens +1.0 diopter **	0700500961
	Savage A50 LUX Magnifying Lens +1.5 diopter **	0700500962
	Savage A50 LUX Magnifying Lens +2.0 diopter **	0700500963
	Savage A50 LUX Magnifying Lens +2.5 diopter **	0700500964

* HC Lenses include an anti-scratch hard coat for longer life.

** Magnifying Lenses are optional accessories not included with the complete helmet.

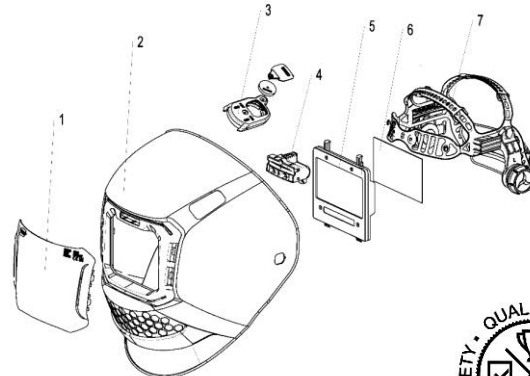

ESAB / esab.com

